

## eNewsletter Advertising

SAE's eNewsletter products are a top vehicle for generating leads and awareness, and are written specifically to meet the information needs of the engineer/manager. Relevant editorial content motivates the audience to subscribe, as each eNewsletter has a different focus and mission. Two offerings are available for the aerospace sector:

### Technology eNewsletters

From the editors of AEM magazine, the technology eNewsletters contain original content focused on key aerospace technologies. Recipients are hand-selected from over 330,000 contacts<sup>1</sup> in the SAE worldwide customer database, ensuring high response rates from your key prospects. Traditional banner and sponsored link positions are available.

### Aerospace Industry eNewsletters

These eNewsletters reach a wide distribution within the vertical industry segment and contain customer-driven news of SAE products and services available for continuing education, industry events, standards upgrades/changes and more — all of which are critical to the engineering professional.



## 2009 Technology eNewsletters<sup>2</sup> from the Editors of AEM

Dates below are the deadlines for Insertion Orders and Materials.

	SAE Vehicle Engineering <sup>3</sup>	Aerospace Manufacturing	Materials <sup>4</sup> <b>NEW!</b>
<b>Frequency</b>	6x	8x	6x
<b>Distribution</b>	200,000	15,000	20,000
<b>January</b>	December 22		
<b>February</b>		February 12	February 5
<b>March</b>	February 19	March 19	
<b>April</b>		April 16	April 9
<b>May</b>	April 23		
<b>June</b>		June 18	June 4
<b>July</b>	June 25		
<b>August</b>		August 13	August 6
<b>September</b>	August 20	September 10	
<b>October</b>		October 15	October 8
<b>November</b>	October 22		
<b>December</b>		December 10	December 3
<b>Advertising Positions</b>	<b>Gross Rates</b>		
<b>1</b>	\$3,850	\$1,800	\$1,900
<b>3 or 4</b>	\$2,695	\$1,260	\$1,330
<b>5, 6, 7</b>	\$2,310	\$1,175	\$1,240
<b>Text Banner <b>NEW!</b></b>	\$3,000	\$1,440	\$1,460
<b>Sponsored Link* <b>NEW!</b></b>	\$1,000	\$300	\$375

\* Multiple opportunities available for sponsored links.

Continuity discounts available for contracting six or more eNewsletter placements; contact your representative for details.

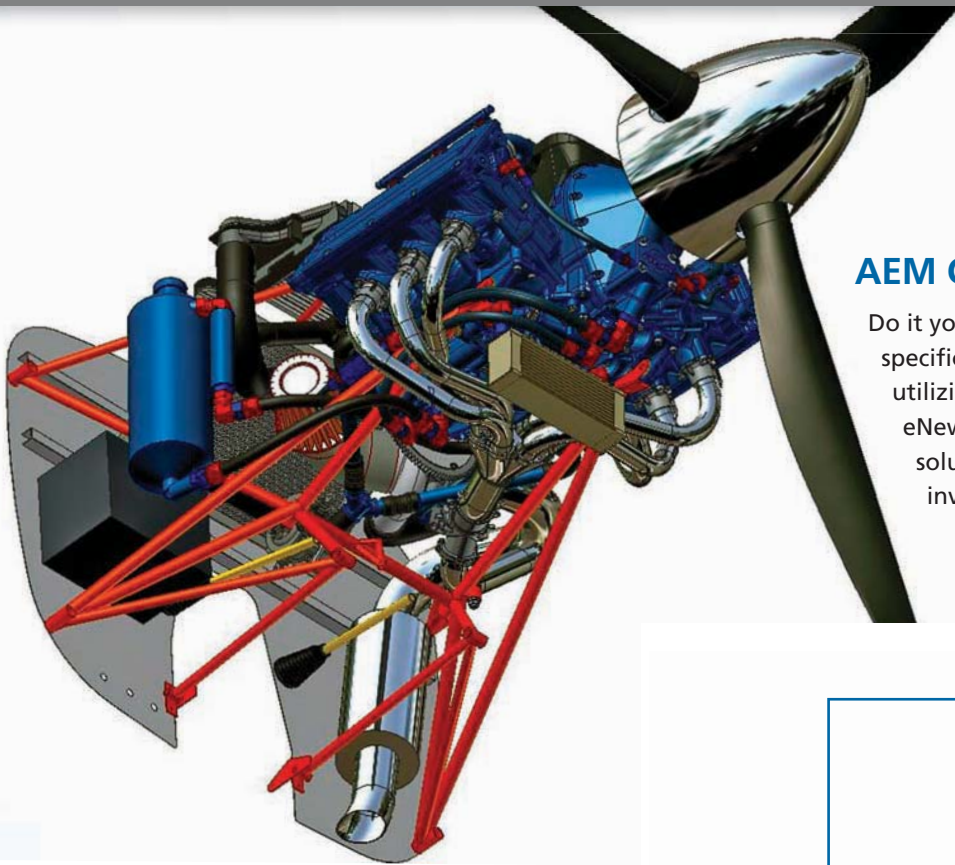

## AEM Custom Single-Sponsored eNewsletters

Do it your way by sponsoring an eNewsletter focused on your specific technology offerings. Produced by the SAE editorial team, utilizing your content and relevant SAE content, the custom eNewsletter reaches targeted buyers interested in your business solution. Receive a 100% share of voice exclusivity for a gross investment starting at \$7,900.

### Aerospace Industry eNews

12x
50,000
January 6
February 3
March 3
April 7
May 5
June 2
July 7
August 4
September 8
October 6
November 3
December 1
\$1,450
\$1,000
\$925
n/a
n/a

Ad Position 1

Text Banner Ad

Sponsored Link

Ad Positions from top to bottom: 3, 4, 5, 6, and 7

<sup>1</sup> Publisher's own data.

<sup>2</sup> eNewsletter titles available in other markets: Automotive Electronics, Automotive Testing & Simulation, Automotive Powertrain, Diesel, Truck & Bus, Hybrid & Electric Vehicle, Off-Highway.

<sup>3</sup> Highlights of the latest global developments in the automotive, aerospace, off-highway and truck & bus industries – formerly SAE Technology eNewsletter.

<sup>4</sup> Materials developments in the automotive, aerospace, off-highway and truck & bus industries.